

SIDNEY MANUFACTURING

SIDE WALL RETURN™ DRAG CONVEYOR INSTALLATION INSTRUCTIONS

NOTICE

**BEFORE ANY MAINTENANCE OR SERVICE IS PERFORMED ON
THIS DRAG CONVEYOR, IT MUST BE LOCKED OUT IN
ACCORDANCE WITH CURRENT OSHA AND NEC
REQUIREMENTS!**

Sidney Manufacturing Company

405 North Main Street Sidney, Ohio 45365

PH# : (937) 492-4154 FAX# : (937) 492-0919

Toll Free 1 - 800-482-3535

SAFETY RESPONSIBILITY

It is the responsibility of the contractor, installer, owner and user to supplement the materials and services furnished by The Sidney Manufacturing Company with the necessary items to make the conveyor installation comply with all laws. Electrical controls, machinery guards, inspection doors guards and conveyor lids, clear walkways and proper railings are some of the necessary items for a safe work site.

The Side Wall Return Drag Conveyors are not normally designed to handle hazardous materials or operate in a hazardous environment. Hazardous materials can be those that are explosive, flammable or toxic. Special designs and constructions must be fabricated for these situations. Sidney Manufacturing Co. should be consulted for all such installations.

SAFETY

1. Side Wall Return Drag Conveyors should be completely enclosed and all safety guards in place before powering up the conveyor. If the conveyor needs to be opened for inspection, cleaning or observation, the motor driving units needs to be locked out electrically in accordance to OSHA standards. This needs to be done in such a manner that the conveyor cannot be restarted by anyone, however remote the location from the area without the conveyor housing being put back into position and all guards put into proper place.
2. The conveyor is designed for specific purposes. Do not use the conveyor for anything but what it was designed to handle and do not overload the conveyor beyond its capacity. Do not walk on the top of the conveyor, do not remove any safety guards, do not place hands or feet in any of the conveyor openings.
3. The warning label shown below is secured to all Side Wall Return Drag Conveyor covers, inspection doors, end relief doors, and all head and tail sections of the conveyor.



4. Always keep the areas around the conveyor and drive units free and clear at all times.
5. If the owner or installer needs help designing a safe installation or a safe work place, Sidney Manufacturing Company will be glad to assist in the selection of special devices or special equipment.

SIDNEY MANUFACTURING'S SWR DRAG CONVEYOR

Installation Instructions

Drag type conveyors unlike screw type conveyors must be perfectly aligned at the flanges during the assembly process. Misalignment at the flange connection will cause the paddles to catch and jump, multiplied by every paddle and every bolted flange connection, resulting in tremendous noise and vibration. Damaged paddles could result effecting the final clean out of product in the conveyor. Each trough section must be perfectly matched at each flange location, to insure a smooth travel surface for paddles. End flanges are fabricated on a computer controlled high definition plasma machine. This results in a proper part of exact quality. Flanges are welded to trough in a flanging machine that squares each trough exactly to its flanges. With this process of precision flanges being welded on square conveyor troughs, the installer will be able to align the troughs at the job site. Use the following instructions to install the conveyor properly.

Please feel free to contact **Sidney Manufacturing Company** if you have any questions about the installation, operation or maintenance of your Side Wall Return Drag Conveyor.

Phone Numbers: (800) 482-3535 Fax Number: (937) 492-0919
(937) 492-4154

Installation of this drag conveyor must be done by personnel experienced in the installation of drag conveyors and familiar with general safety practices and State and Federal (OSHA) regulations pertaining to the construction industry that must be followed.

- 1.) **Start by looking over the assembly print.** This will show you the placement and proper sequence the trough sections will need to be installed in. It will also show you proper location of all inlets and discharges and any special items on the conveyor.
- 2.) Bolt trough sections together. **There are 5 critical surfaces that must be perfectly aligned. See diagram below.** To assist in this process use a drift punch to help align these surfaces. Start by aligning the bottom of the trough and working your way up each side of the flange. See surfaces marked A,B & C. These surfaces aligned first and secured with tightened bolts will help the remainder of the trough sides to line up easier. Continue this process until all trough sections are bolted together. Be sure to support the conveyor at a flange location every 20' or less. Support feet are supplied and manufacturers recommended locations are shown on the assembly prints. **Be sure to use silicone caulking between all bolted conveyor connections.**

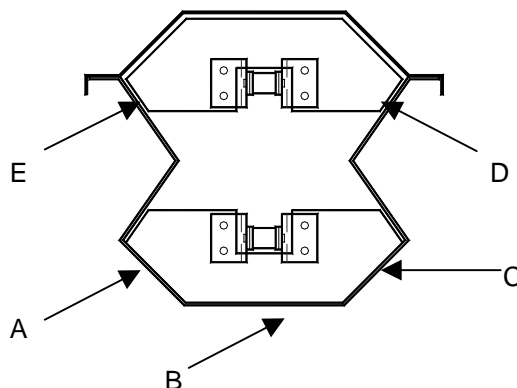

- 3.) Repeat step (2) when connecting the trough to the head section and to the tail section. Being sure to watch the five critical surfaces. When applicable the same process needs to be followed when bolting on by-pass inlet sections.
- 4.) Assemble paddles to chain. Use drawing D010-01 for proper placement of paddle on chain attachments. **Be sure not to fully tighten bolts at paddle connection at this time.** The bolts should only be finger tight so the paddles remain loose on the chain attachments.
- 5.) Feed chain into the lower trough of the conveyor through the head discharge. Be sure you are placing the trough chain into the conveyor so the paddles will be in proper placement in relation to the product flow. (See drawing D010-01) Feed the chain into the trough working it toward the tail section. Connecting chain sections as you proceed.
- 6.) Feed chain around tail sprocket so paddles start to appear in the return area of trough. Fill the return area with assembled chain. Be sure to turn chain over so paddles are in an upside down position.
- 7.) Connect chain and let take-up out to desired chain tightness. See drawing D011-01 on take-up detail for instructions and proper operation of take-up.
- 8.) Let paddles settle to the bottom of trough. **Tighten paddles inside the lower portion of the trough along the whole bottom of the conveyor.** (or at least most of this area) Mark the first and last paddles tightened. This may be done by leaving the next paddle off the next attachment. Rotate the conveyor to allow another group of paddles to fall into the lower trough area and tighten these. If it is not possible to manually rotate the tight paddles to return area and loose paddles to bottom trough area, it will have to be done under power. It is absolutely necessary to put all covers and guards in place prior to operating. Following this procedure, power must be locked out in accordance to OSHA lock out / tag out regulations before removing lids and guards. Mark last paddle done. Repeat sequence until all paddles are tight. **This process is very important. Unlike round bottom drag conveyors, the Side Wall Return Drag Conveyors paddles must all be aligned with each other before they are tightened to the chain. This is necessary for proper return of the paddles on the side wall. For this reason do not tighten paddles to chain attachments outside the conveyor trough and always use the bottom of the conveyor trough as the alignment area. Proper positions of the paddles in the trough also ensures full clean out of the conveyor.**
- 9.) Place lids on the conveyor. Reference the assembly print for proper inlet locations and joint cover locations.

MAINTENANCE

After the conveyor is in operation and performing properly, only periodic inspections are necessary to ensure against unexpected failures or problem areas. Bearing lubrication, flight wear, chain and sprocket wear should be checked at these times. Tightness of the chain should be checked every 24 hours of operation until the initial stretch has been eliminated. Conduct periodic inspections of the entire conveyor and make a written maintenance schedule log for the conveyor.

Gate Mounting Instructions

Gates **must** be mounted on the trough per these instructions to ensure a proper fit.

Gates **must** be mounted before installing the drag conveyor.

All gates are match marked to a trough section, mount the proper gate to the proper trough

The trough is stamped on the trough gate mounting flange

The gate is stamped on the lower gate side flange toward the rear of the gate.

- 1.) Turn trough over so that cutout opening in trough is facing up. Remove the factory mounted rubber wiper seal. Place gate on trough ensuring that the side of trough with bolts in and the extended portion of gate are on the same side.

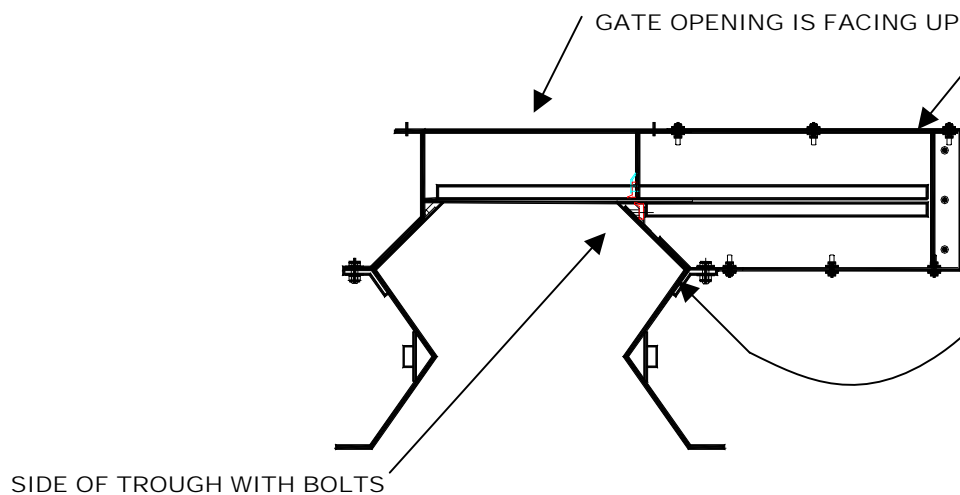

- 2.) Use C-clamps to draw the gate down to conform to the trough. These clamps are positioned in the actual gate trough opening. See sketch.

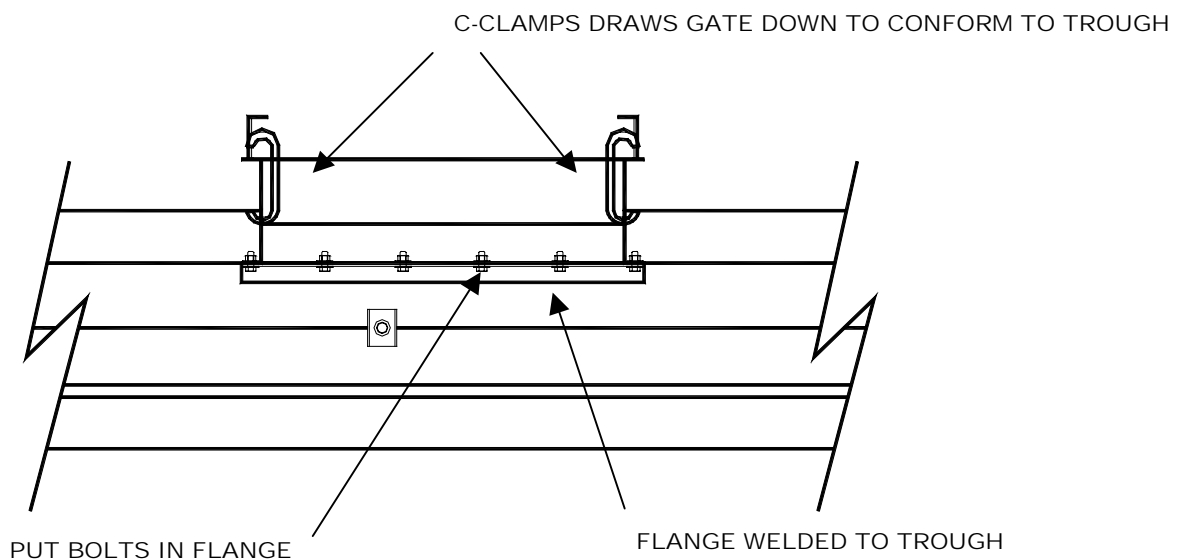

3.) While clamps are in position, bolt the gate to the flange that is welded to the trough. Use 3/8" X 1 1/4" bolts with flat washers and lock washers on each gate.

4.) Mount the rubber wiper seals. The bolts were secured with temporary thread lock so that the bolts would not vibrate loose in shipment. This bond can be broken. The prepunched rubber seal gets mounted in the position shown below. Upper seal bolts are threaded into the trough piece. The lower bolts extend through the gate and require washers, lock washers and nuts. There is a wiper seal retainer supplied. This acts as a stiffener to the rubber to keep the bolt from sinking into the rubber seal. **Be sure to install the top and bottom seal.** This seals the gate from leaking back into the gate housing.

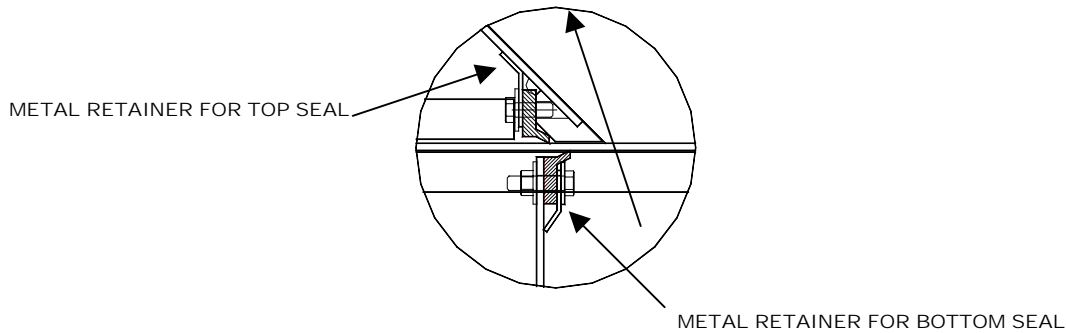

5.) Mount air cylinder to gate and connect it to the slide. Run the gate with air to make sure everything lines up properly.

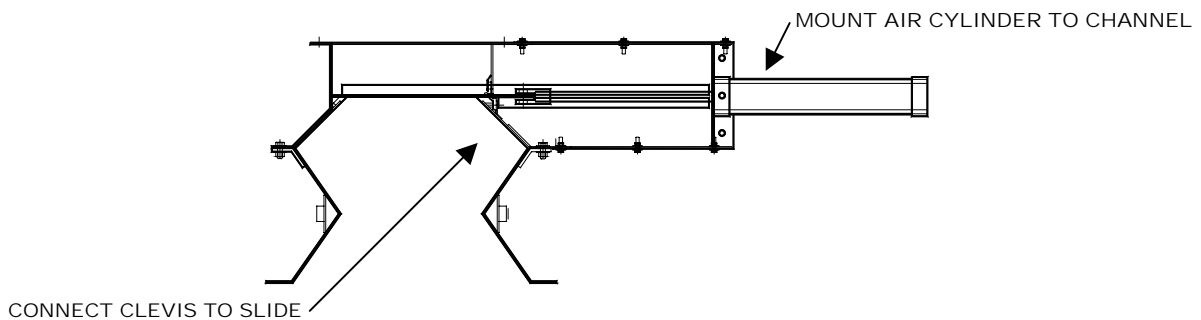

6.) The connection point where the gate meets up to the trough, needs caulked. This finishes sealing the gate area. A weld of permanent connection of some sort is not recommended. The gate may need to be removed or replaced in the future. Caulking the area would allow for this. Any connecting line between the trough and gate needs to be caulked with silicone. The clear silicone was supplied with the trough and gate shipment.

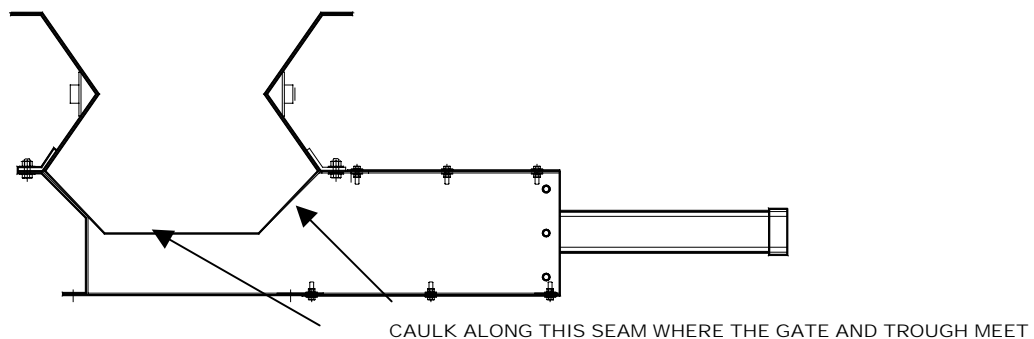

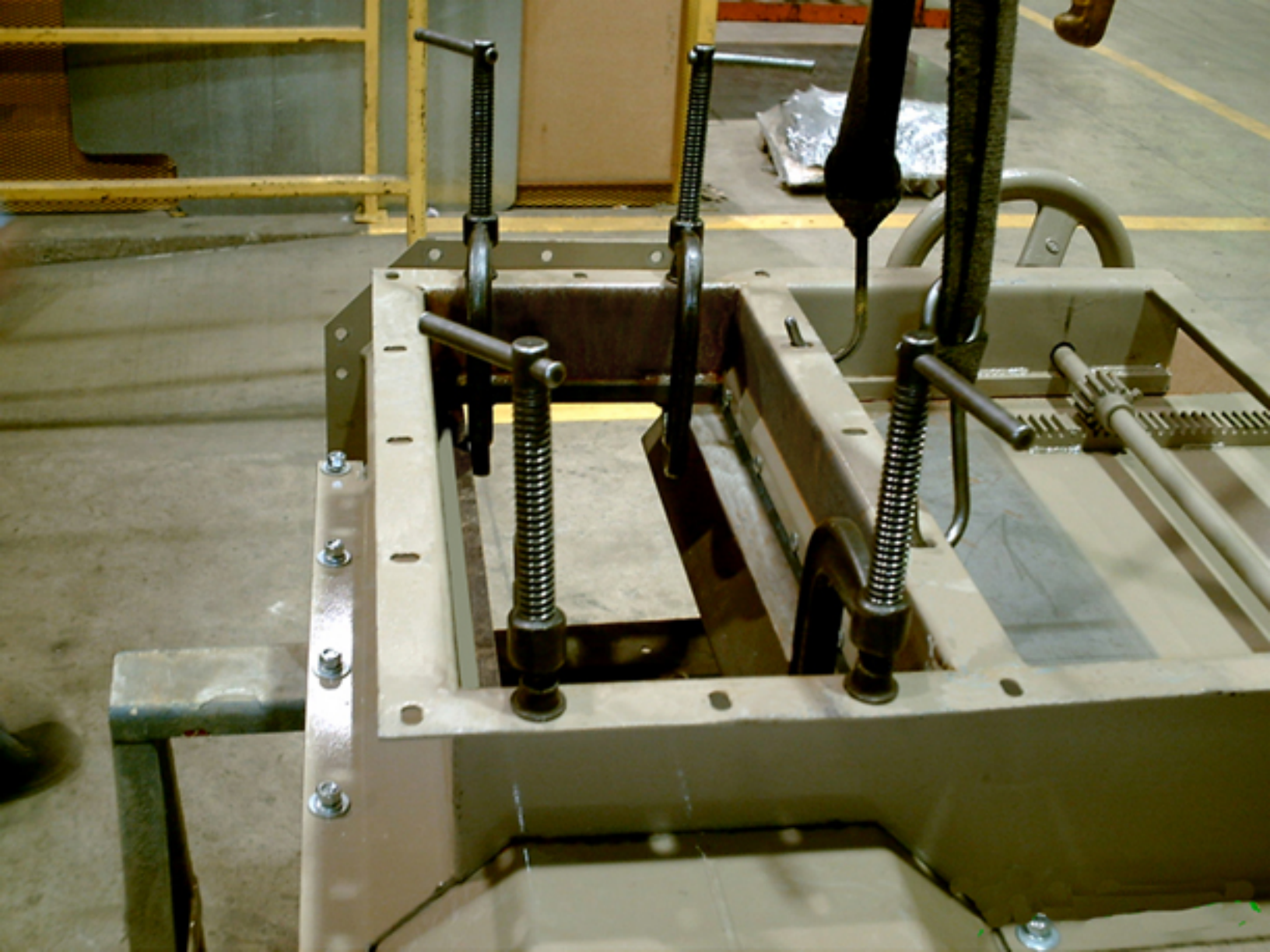



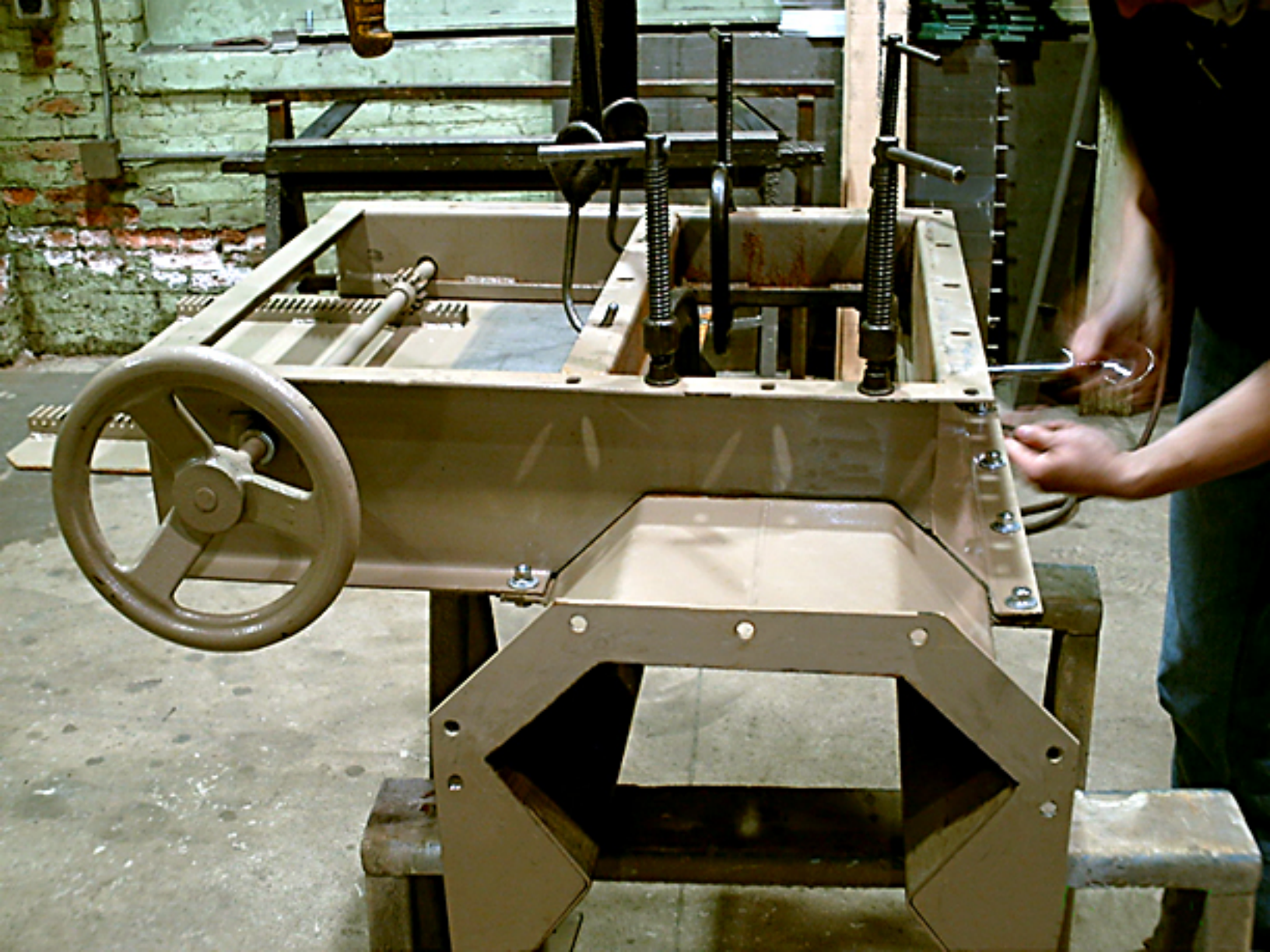

<PADDLE SHOULD TOUCH ON GUSSETS 1-2 INCHES FROM FRONT OF HEAD DISCHARGE>

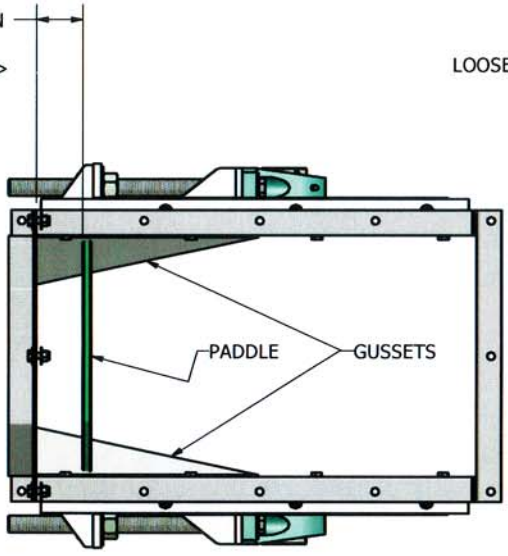

TOP VIEW OF HEAD DISCHARGE

IF PADDLE IS NOT TOUCHING GUSSET AT ALL, THEN CHAIN IS TOO TIGHT.

LOOSEN CHAIN TO PROPER TENSION.

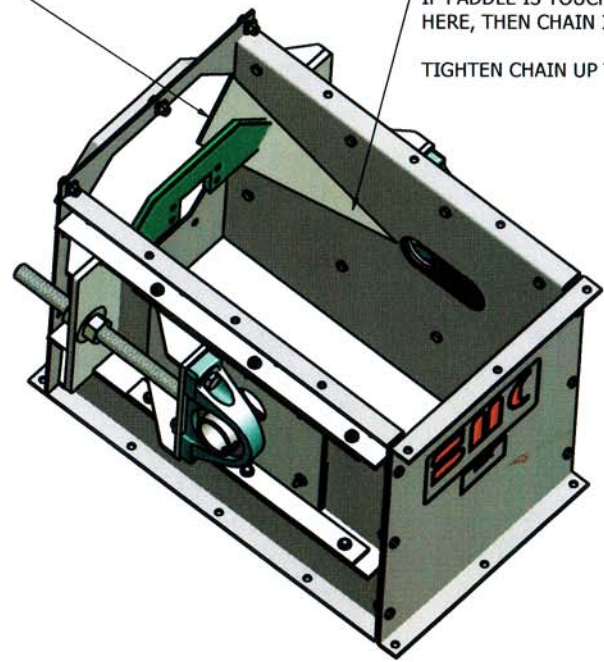

IF PADDLE IS TOUCHING BACK HERE, THEN CHAIN IS TOO LOOSE.

TIGHTEN CHAIN UP TO PROPER TENSION

ENGINEER RMJ	7/12/2006	 <small>QUALITY PRODUCTS BUILT BY QUALITY PEOPLE</small>	
SO#			
SOLD TO		TITLE	
SHIP TO		PROPER CHAIN TENSION	
LOCATION		SIZE	DWG NO
		B	Proper Chain Tension
		SCALE	REV
			SHEET 1 OF 1

MATERIAL FLOW →

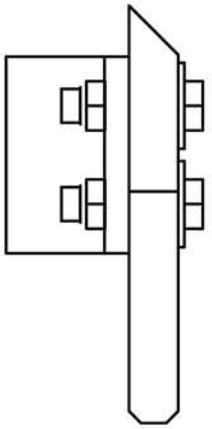

SIDE VIEW OF ASSEMBLY

MATERIAL FLOW →

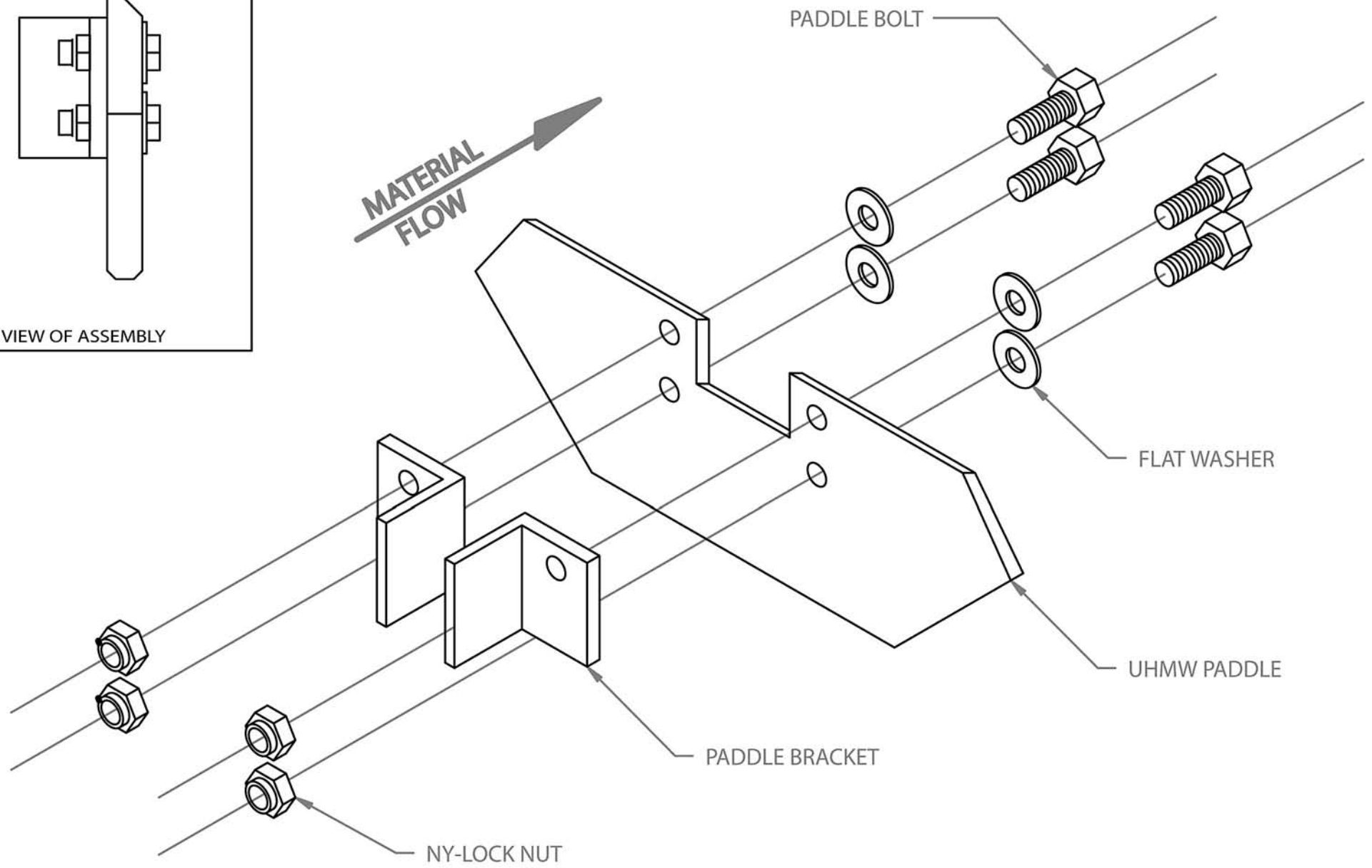

PADDLE BOLT

FLAT WASHER

UHMW PADDLE

PADDLE BRACKET

NY-LOCK NUT

To remove excessive chain slack you must adjust the take-up assembly. The Side Wall Return Drag Conveyors are supplied with a minimum of a 4" take-up. The take-up assembly may be located on the tail section or on the head section, depending on the conveyor purchased. To adjust take up, first loosen nut "A" and then turn nut "B" in the proper direction to take the slack out of the chain. Adjust each side a little at a time to get even adjustment on both sides of the take-up. Be sure to check dimension "X" is equal on both sides of the take-up assembly. Once the slack in the chain has been removed and you have checked both sides that dimension "X" is equal, tighten nut "A" to take-up plate. This will lock the nuts in position and not allow the take-up assembly to move.

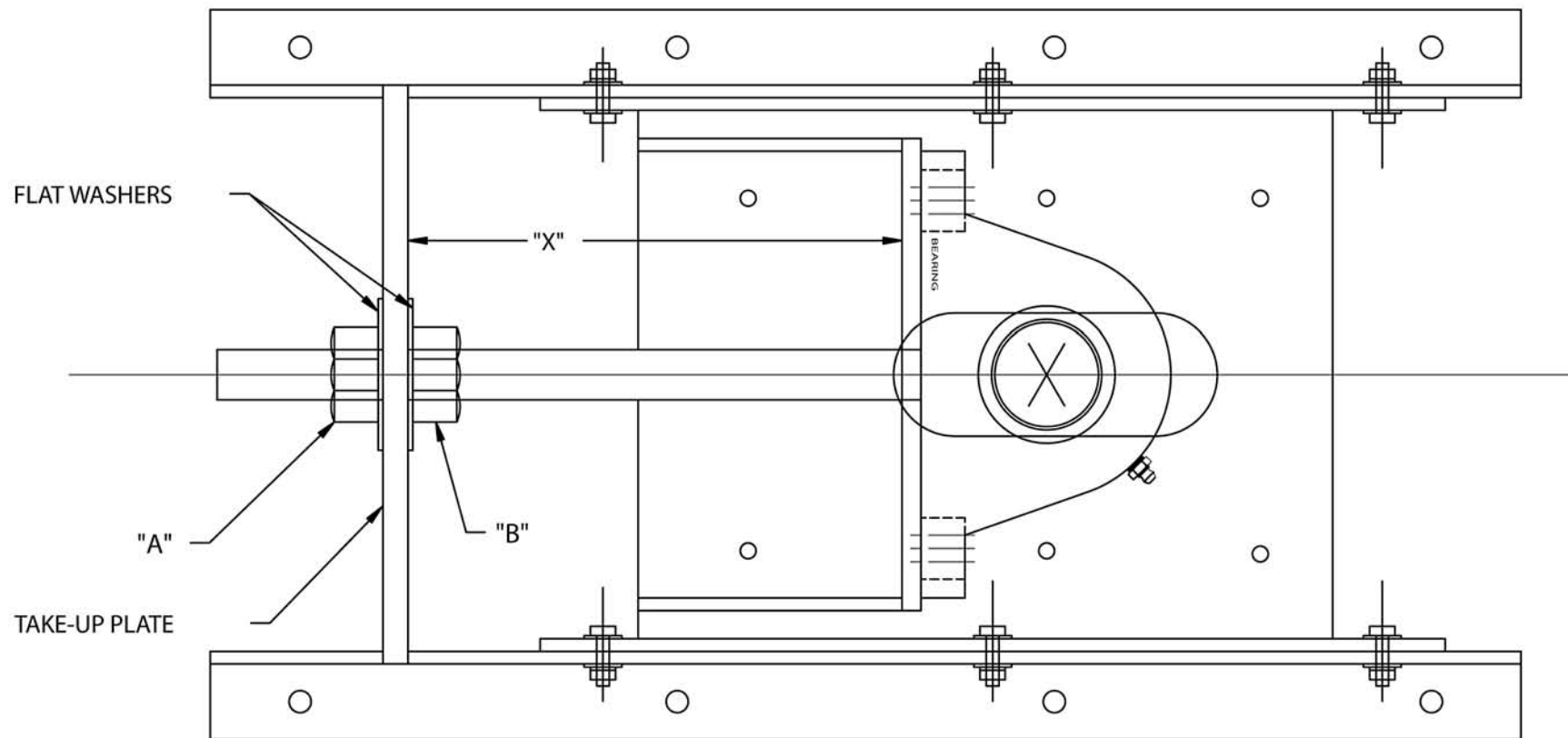

TAKE-UP ASSEMBLY DETAIL